

FalconLift®

www.falconlift.com

FULL ELECTRIC STACKER **"Punto" series**

1500 Kg



Conforms to EN1757-1 : 2001, EN1727

- **Disegno ergonomico - montante di qualità superiore**
Heavy duty design and top quality mast construction
Design ergonomique - mât de qualité supérieure
- **Massima sicurezza e comfort per l'operatore**
Outstanding comfort and safety for the driver
Grand confort d'utilisation
- **Controllo elettronico "Curtis", centralina idraulica e motoriduttore europei**
"Curtis" electronic control system, power pack and drive wheel made in Europe
Système électronique "Curtis", groupes moteur et levage de construction Européenne
- **Contaore e controllo scarica batteria "Curtis"**
Hourmeter and battery discharge indicator
Horametre et contrôleur de charge "Curtis"
- **Timone "Rema"**
"Rema" tiller
Timon "Rema"



MODELLO / MODEL / MODELE		FLPUNTO1529	FLPUNTO1533
Portata / Capacity / Capacité		1500 kg	
Alt. max forche / Max. forks height / Hauteur de levee		2900 mm	3300 mm
Alt. min. forche / Min. forks height / Hauteur fourches min.		90 mm	
Lunghezza forche / Forks length / Longueur fourches		1150 mm	
Larghezza forche / Overall forks width / Largeur fourches		540 mm	
Baricentro / Load Center / Centre de gravité		600 mm	
Ruota motrice / Drive wheel / Roue directionnelle		Ø 250 mm - 600 W - 24 V	
Elettropompa / Power Pack / Moteur de levage		2 Kw - 24 V	
Batteria di trazione / Traction Battery / Batterie de traction		150 Ah - 24 V	
Carica Batt. / Battery Charger / Chargeur		25Ah - 24 V	
Peso Netto / Net Weight / Poids		680 Kg	700 Kg
Dimensioni / Overall Dimensions / Dimensions	X2	190 mm	
	L2	774 mm	
	h1	2025 mm	2025 mm
	h4	3546 mm	3946 mm
	X	455 mm	
	Y	1279 mm	
	L	1924 mm	
	N	160 mm	
	h3	2900 mm	3300 mm
	Wa	1540 mm	

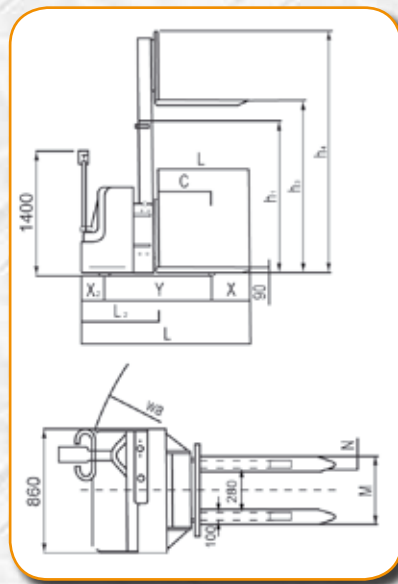

Fornibile anche in versione 1200 Kg
Available also with 1200 Kg version
Disponibile en option 1200 Kg

DEALER