

FalconLift®



www.falconlift-mh.com

POWERED PALLET TRUCK **"Teo" series**



Conforms to EN1726, EN1175-1

- **Disegno ergonomico**
Heavy duty design and top quality
Design ergonomique
- **Massima sicurezza e comfort per l'operatore**
Outstanding comfort and safety for the driver
Grand confort d'utilisation
- **Controllo elettronico "Curtis", centralina idraulica e motoriduttore europei**
"Curtis" electronic control system, power pack and drive wheel made in Europe
Système électronique "Curtis", groupes moteur et levage de construction Européenne

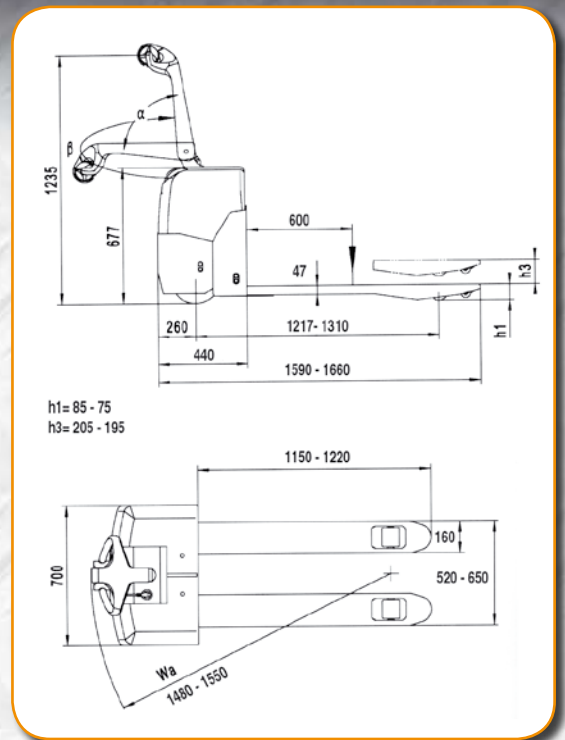

MODELLO / MODEL / MODELE	FLTEO15SA	FLTEO15LA
Portata / Capacity / Capacité	1500 kg	
Baricentro / Load Center / Centre de gravité	600 mm	
Alt. max forche / Max. forks height / Hauteur de levee	205 mm	
Alt. min. forche / Min. forks height / Hauteur fourches min.	85 mm	
Lunghezza forche / Forks length / Longueur fourches	1150 - 1220 mm	
Larghezza forche / Overall forks width / Largeur fourches	520 mm	650 mm
Larghezza forca / Individual fork width / Largeur individuel.	160 mm	
Interasse ruote / Wheel base / Base de roue	1217 - 1310 mm	
Raggio sterzo / Turning radius / Rayon de braquage	1480 - 1550 mm	
Traslazione / Traveling speed with, without load / Vitesse	5.0 / 5.2 Km/h	
Sollevamento / Lifting speed with, without load / Levaé	35 mm/s	
Discesa / Lowering speed / Vitesse de descente	27 mm/s	
Ruota motrice / Drive wheel / Roue directionelle	700 W, Ø 252 mm	
Elettropompa / Power Unit / Moteur de levage	800 W/24V	
Batteria / Battery / batterie	24V/80Ah, 48Kg	
Carica Batt. / Battery Charger / Chargeur	ON BOARD	
Dimensioni / Overall Dimensions / Dimension	L 1590 - 1660 x 700 mm	
Peso Netto / Net Weight / Poids	270 Kg	270 Kg



DEALER